

ГОСТ 17378—2001
(ИСО 3419—81)

МЕЖГОСУДАРСТВЕННЫЙ СТАНДАРТ

**Детали трубопроводов бесшовные приварные
из углеродистой и низколегированной стали**

ПЕРЕХОДЫ

Конструкция

Издание официальное



Москва
Стандартинформ
2010

Предисловие

1 РАЗРАБОТАН ОАО «Корпорация МОНТАЖСПЕЦСТРОЙ»

ВНЕСЕН Государственным комитетом Российской Федерации по стандартизации и метрологии

2 ПРИНЯТ Межгосударственным советом по стандартизации, метрологии и сертификации (протокол № 20 от 1 ноября 2001 г.)

За принятие проголосовали:

Наименование государства	Наименование национального органа по стандартизации
Азербайджанская Республика	Азгосстандарт
Республика Армения	Армгосстандарт
Республика Беларусь	Госстандарт Республики Беларусь
Грузия	Грузстандарт
Республика Казахстан	Госстандарт Республики Казахстан
Кыргызская Республика	Кыргызстандарт
Республика Молдова	Молдовастандарт
Российская Федерация	Госстандарт России
Республика Таджикистан	Таджикстандарт
Туркменистан	Главгосслужба «Туркменстандартлары»
Республика Узбекистан	Узгосстандарт
Украина	Госстандарт Украины

Изменение № 1 принято Межгосударственным советом по стандартизации, метрологии и сертификации (протокол № 29 от 24 июня 2006 г.)

За принятие изменения проголосовали национальные органы по стандартизации следующих государств: AM, KZ, KG, MD, RU, TJ, UZ, UA [коды альфа-2 по МК (ИСО 3166) 004]

3 Стандарт соответствует ИСО 3419—81 «Фитинги из легированной и нелегированной стали приварные встык» в части конструкции переходов

4 Постановлением Государственного комитета Российской Федерации по стандартизации и метрологии от 27 мая 2002 г. № 205-ст межгосударственный стандарт ГОСТ 17378—2001 (ИСО 3419—81) введен в действие в качестве государственного стандарта Российской Федерации с 1 января 2003 г.

5 ВЗАМЕН ГОСТ 17378—83

6 ИЗДАНИЕ (ноябрь 2009 г.) с Изменением № 1, принятым в апреле 2007 г. (ИУС 7—2007)

© ИПК Издательство стандартов, 2002
© СТАНДАРТИНФОРМ, 2010

Настоящий стандарт не может быть полностью или частично воспроизведен, тиражирован и распространен в качестве официального издания на территории Российской Федерации без разрешения Федерального агентства по техническому регулированию и метрологии

Детали трубопроводов бесшовные приварные из углеродистой
и низколегированной стали

ПЕРЕХОДЫ

Конструкция

Carbon and low-alloy steel butt-welding fittings. Reducers. Design

Дата введения 2003—01—01

1 Область применения

Настоящий стандарт распространяется на бесшовные приварные концентрические и эксцентрические переходы из углеродистой и низколегированной стали.

Область применения переходов — в соответствии с разделом 1 ГОСТ 17380.

Требования пунктов 4.1 — 4.3 и раздела 5 являются обязательными, остальные требования — рекомендуемыми.

2 Нормативные ссылки

В настоящем стандарте использована ссылка на ГОСТ 17380—2001 (ИСО 3419—81) Детали трубопроводов бесшовные приварные из углеродистой и низколегированной стали. Общие технические условия

3 Определения, обозначения и сокращения

Термины, их определения, обозначения и сокращения — по ГОСТ 17380.

4 Конструкция и размеры

4.1 Конструкция и размеры переходов должны соответствовать указанным на рисунке 1 и в таблицах 1 и 2.



Рисунок 1

ГОСТ 17378—2001

Т а б л и ц а 1 — Переходы исполнения 1

Размеры в миллиметрах

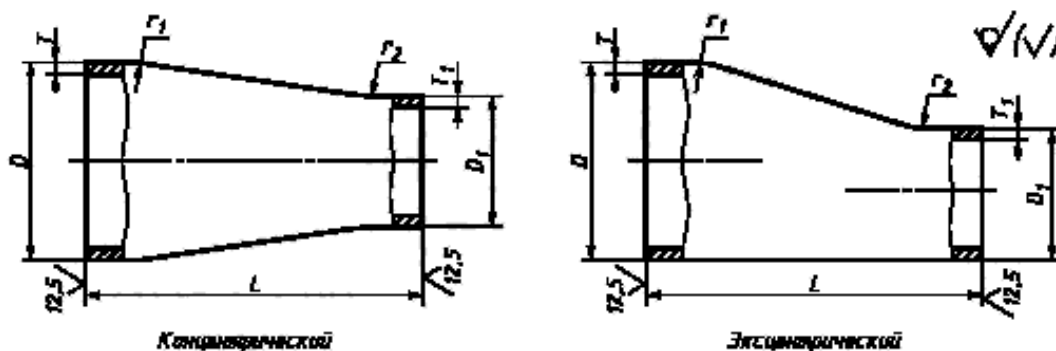
DN	D	T	D ₁	T ₁	L	Масса, кг
20	26,9	2,0	21,3	2,0	38	0,05
		3,2		3,2		0,07
		4,0		4,0		0,09
25	33,7	2,3	21,3	2,0	51	0,09
		3,2		3,2		0,12
		4,5		4,0		0,16
		2,3	26,9	2,0		0,09
		3,2		3,2		0,12
		4,5		4,0		0,16
32	42,4	2,6	21,3	2,0	51	0,13
		3,6		3,2		0,17
		5,0		4,0		0,23
		2,6	26,9	2,0		0,13
		3,6		3,2		0,17
		5,0		4,0		0,23
		2,6	33,7	2,3		0,13
		3,6		3,2		0,17
		5,0		4,5		0,23
40	48,3	2,6	26,9	2,0	64	0,19
		3,6		3,2		0,25
		5,0		4,0		0,34
		2,6	33,7	2,3		0,19
		3,6		3,2		0,25
		5,0		4,5		0,34
		2,6	42,4	2,6		0,19
		3,6		3,6		0,25
		5,0		5,0		0,34
50	60,3	2,9	33,7	2,3	76	0,31
		4,0		3,2		0,42
		5,6		4,5		0,58
		2,9	42,4	2,6		0,31
		4,0		3,6		0,42
		5,6		5,0		0,58
		2,9	48,3	2,6		0,31
		4,0		3,6		0,42
		5,6		5,0		0,58
65	76,1	2,9	42,4	2,6	89	0,47
		5,0		3,6		0,78
		7,1		5,0		1,10
		2,9	48,3	2,6		0,47
		5,0		3,6		0,78
		7,1		5,0		1,10

Продолжение таблицы 1

Размеры в миллиметрах

DN	D	T	D ₁	T ₁	L	Масса, кг
65	76,1	2,9	60,3	2,9	89	0,47
		5,0		4,0		0,78
		7,1		5,6		1,10
80	88,9	3,2	48,3	2,6		0,60
		5,6		3,6		1,00
		8,0		5,0		1,40
		3,2	60,3	2,9		0,60
		5,6		4,0		1,00
		8,0		5,6		1,40
100	114,3	3,2	76,1	2,9	0,60	
		5,6		5,0	1,00	
		8,0		7,1	1,40	
100	114,3	3,6	60,3	2,9	102	1,00
		6,3		4,0		1,70
		8,8		5,6		2,30
		3,6	76,1	2,9		1,00
		6,3		5,0		1,70
		8,8		7,1		2,30
125	139,7	3,6	88,9	3,2	1,00	
		6,3		5,6	1,70	
		8,8		8,0	2,30	
125	139,7	4,0	76,1	2,9	127	1,70
		6,3		5,0		2,60
		10,0		7,1		4,10
		4,0	88,9	3,2		1,70
		6,3		5,6		2,60
		10,0		8,0		4,10
150	168,3	4,0	114,3	3,6	1,70	
		6,3		6,3	2,60	
		10,0		8,8	4,10	
150	168,3	4,5	88,9	3,2	140	2,50
		7,1		5,6		3,90
		11,0		8,8		6,00
		4,5	114,3	3,6		2,50
		7,1		6,3		3,90
		11,0		8,8		6,00
200	219,1	4,5	139,7	4,0	2,50	
		7,1		6,3	3,90	
		11,0		10,0	6,00	
200	219,1	6,3	114,3	3,6	152	5,10
		8,0		6,3		6,30
		12,5		8,8		9,70

ГОСТ 17378—2001

Продолжение таблицы 1

Размеры в миллиметрах

DN	D	T	D ₁	T ₁	L	Масса, кг
200	219,1	6,3 8,0 12,5	139,7	4,0 6,3 10,0	152	5,10 6,30 9,70
		6,3 8,0 12,5	168,3	4,5 7,1 11,0		5,10 6,30 9,70
250	273,0	6,3 10,0	139,7	4,0 6,3	178	7,40 12,00
		6,3 10,0	168,3	4,5 7,1		7,40 12,00
		6,3 10,0	219,1	6,3 8,0		7,40 12,00
300	323,9	7,1 10,0	168,3	4,5 7,1	203	11,00 16,00
		7,1 10,0	219,1	6,3 8,0		11,00 16,00
		7,1 10,0	273,0	6,3 10,0		11,00 16,00
350	355,6	8,0 11,0	219,1	6,3 8,0	330	23,00 31,00
		8,0 11,0	273,0	6,3 10,0		23,00 31,00
		8,0 11,0	323,9	7,1 10,0		23,00 31,00
400	406,4	8,8 12,5	273,0	6,3 10,0	356	31,00 43,00
		8,8 12,5	323,9	7,1 10,0		31,00 43,00
		8,8 12,5	355,6	8,0 11,0		31,00 43,00
450	457,0	10,0	323,9	7,1	381	42,00
			355,6	8,0		
			406,4	8,8		
500	508,0	11,0	355,6	8,0	508	65,00
			406,4	8,8		
			457,0	10,0		

Окончание таблицы 1

Размеры в миллиметрах

DN	D	T	D ₁	T ₁	L	Масса, кг
600	610,0	12,5	406,4	8,8	508	94,0
			457,0	10,0		
			508,0	11,0		
700	711,0	—	457,0	10,0	610	—
			508,0	11,0		
			610,0	12,5		
800	813,0		508,0	11,0		
			610,0	12,5		
			711,0	—		
900	914,0		610,0	12,5		
			711,0	—		
			813,0	—		
1000	1016,0		711,0	—		
			813,0	—		
			914,0	—		
Примечание — Масса приведена для справок.						

Таблица 2 — Переходы исполнения 2

Размеры в миллиметрах

DN	D	T	D ₁	T ₁	L	Масса, кг			
32	38	2,0	32	2,0	30	0,1			
		3,0		3,0		0,2			
		4,0		4,0		0,2			
		2,0	25	1,6		0,1			
		3,0		3,0		0,2			
		4,0		3,0		0,2			
40	45	2,5	32	1,6	45	0,1			
		4,0		3,0		0,2			
		5,0		3,0		0,3			
		2,5	38	2,0		0,1			
		4,0		4,0		0,2			
		5,0		5,0		0,3			
		50	57	2,5		25	2,0	45	0,1
				4,0			4,0		0,2
				5,0			5,0		0,3
3,0	25			1,6	0,2				
4,0				1,6	0,3				
5,0				3,0	0,3				
		6,0		3,0		0,4			

DN	D	T	D ₁	T ₁	L	Масса, кг			
50	57	3,0	32	2,0	45	0,2			
		4,0		2,0		0,3			
		5,0		3,0		0,3			
		6,0		4,0		0,4			
		3,0	38	2,0		60	0,2		
		4,0		4,0			0,3		
		5,0		4,0			0,3		
		6,0		4,0			0,4		
		3,0	45	2,5			75	0,2	
		3,5		2,5				0,2	
		4,0		3,0				0,3	
		5,0		4,0				0,3	
6,0	5,0	0,4							
3,0	45	2,5	70	0,2					
4,0		2,5		0,3					
5,0		4,0		0,3					
6,0		5,0		0,4					
65	76	3,0		38	2,0	55		0,3	
		3,5			2,5			0,4	
		5,0			3,0			0,6	
		6,0			3,0		0,6		
		7,0		4,0	0,7				
		3,0		45	2,5		70	0,4	
		3,5			2,5			0,5	
		5,0			4,0			0,6	
		6,0	4,0		0,7				
		7,0	5,0		0,8				
		3,0	57	3,0	75			0,3	
		3,5		3,0				0,4	
5,0	4,0	0,6							
6,0	5,0	0,7							
7,0	6,0	0,8							
80	89	3,5	45	2,5		75		0,6	
		6,0		4,0				0,9	
		8,0		5,0			1,2		
		3,5	57	3,0			55	0,6	
		6,0		4,0				0,9	
		8,0		5,0				1,2	
		3,5	76	3,0				75	0,5
		4,0		3,5	0,5				
		6,0		5,0	0,7				
		8,0		6,0	0,9				
		3,5	76	3,5	75				0,6
		6,0		5,0					0,9
8,0	6,0	1,2							

Продолжение таблицы 2

Размеры в миллиметрах

DN	D	T	D ₁	T ₁	L	Масса, кг	
100	108	4,0	57	3,0	80	0,9	
		6,0		4,0		1,2	
		8,0		5,0		1,6	
		9,0		6,0		1,8	
		4,0	76	3,5		0,9	
		6,0		5,0		1,2	
	8,0	6,0	1,6				
	9,0	7,0	1,8				
	114	57	4,0	89		3,5	0,9
			6,0			6,0	1,2
			8,0			8,0	1,6
		9,0	8,0			1,8	
76		4,0	3,0		1,0		
		6,0	4,0		1,3		
	8,0	5,0	1,7				
125	133	9,0	76	6,0	1,9		
		4,0		3,5	1,0		
		6,0		5,0	1,3		
		8,0	6,0	1,7			
		9,0	7,0	1,9			
		100	57	4,0	89	3,5	1,0
8,0				6,0		1,3	
10,0				8,0		1,7	
5,0			8,0	1,9			
8,0			8,0	2,5			
10,0			8,0	3,1			
80		76	5,0	108	4,0	1,3	
	8,0		6,0		1,9		
	10,0		6,0		2,5		
	4,0	4,0	1,6				
	6,0	6,0	2,5				
	8,0	8,0	3,1				
114	57	5,0	114	4,0	1,3		
		8,0		5,0	1,6		
		10,0		7,0	2,0		
	5,0	9,0		2,5			
	6,0	4,5		1,3			
	8,0	5,0		1,6			
10,0	6,0	2,0					
10,0	8,0	2,5					

ГОСТ 17378—2001

Продолжение таблицы 2

Размеры в миллиметрах

DN	D	T	D ₁	T ₁	L	Масса, кг		
125	133	5,0	114	4,0	100	1,6		
		8,0		6,0		2,5		
		8,0		8,0		2,5		
		10,0		9,0		3,1		
150	159	4,5	57	3,0	75	1,5		
		8,0		4,0		2,6		
		10,0		5,0		3,2		
		12,0		6,0		3,9		
		4,5	76	3,5		130	1,5	
		8,0		5,0			2,6	
		10,0		6,0			3,2	
		12,0		7,0			3,9	
		4,5	89	3,5			130	2,3
		8,0		6,0				3,9
		10,0		8,0				4,8
		12,0		8,0				5,9
	4,5	108	4,0	105	2,3			
	8,0		6,0		3,9			
	10,0		8,0		4,8			
	12,0		9,0		5,9			
	4,5	114	4,0		105	2,3		
	8,0		6,0			3,9		
	10,0		8,0			4,8		
	12,0		9,0			5,9		
	5,0	133	4,0			130	2,0	
	6,0		5,0				2,5	
	8,0		6,0				3,1	
	10,0		8,0				3,8	
5,0	133	4,5	130	2,0				
6,0		5,0		2,5				
8,0		7,0		3,1				
10,0		9,0		3,8				
4,5	133	4,0		130	2,3			
8,0		8,0			3,9			
10,0		10,0			4,8			
12,0		10,0			5,9			
168	168	4,5			57	3,0	75	1,6
		8,0				4,0		2,7
		10,0				5,0		3,3
		12,0				6,0		4,0
168	168	4,5	76		3,5	75	1,6	
		8,0			5,0		2,7	
		10,0			6,0		3,3	
		12,0			7,0		4,0	

Продолжение таблицы 2

Размеры в миллиметрах

DN	D	T	D ₁	T ₁	L	Масса, кг
150	168	4,5	89	3,5	130	2,6
		8,0		6,0		4,1
		10,0		8,0		5,1
		12,0		8,0		6,2
		4,5	108	4,0		2,6
		8,0		6,0		4,1
		10,0		8,0		5,1
		12,0		9,0		6,2
		4,5	114	4,0		2,6
		8,0		6,0		4,1
		10,0		8,0		5,1
		12,0		9,0		6,2
4,5	133	4,0	2,6			
8,0		8,0	4,1			
10,0		10,0	5,1			
12,0		10,0	6,2			
200	219	6,0	57	3,0	95	2,9
		10,0		4,0		4,6
		12,0		4,0		5,5
		14,0		5,0		6,4
		16,0		6,0		7,3
		6,0	76	3,5		2,9
		10,0		5,0		4,6
		12,0		5,0		5,5
		14,0		6,0		6,4
		16,0		7,0		7,3
		6,0	89	3,5		2,9
		10,0		5,0		4,6
		12,0		5,0		5,5
		14,0		6,0		6,4
		16,0		8,0		7,3
		6,0	108	4,0		2,9
		10,0		6,0		4,6
		12,0		8,0		5,5
		14,0		8,0		6,4
		16,0		9,0		7,3
		6,0	114	4,0		2,9
		10,0		6,0		4,6
		12,0		8,0		5,5
		14,0		8,0		6,4
16,0	9,0	7,3				
6,0	133	4,0	140	4,4		
10,0		8,0		7,2		
12,0		8,0		8,8		
14,0		10,0		10,0		
16,0		10,0		12,0		

ГОСТ 17378—2001

Продолжение таблицы 2

Размеры в миллиметрах

DN	D	T	D ₁	T ₁	L	Масса, кг			
200	219	6,0	159	4,5	140	4,4			
		10,0		8,0		7,2			
12,0	10,0	8,8							
14,0	12,0	10,0							
16,0	12,0	12,0							
		6,0	168	4,5			4,4		
		10,0		8,0		7,2			
		12,0		10,0		8,8			
		14,0		12,0		10,0			
		16,0		12,0		12,0			
250	273	7,0	108	4,0	140	6,0			
		10,0		6,0		8,5			
		12,0		8,0		10,0			
		14,0		8,0		12,0			
		16,0		9,0		13,0			
		18,0	9,0	15,0					
				7,0		114	4,0		6,0
				10,0			6,0	8,5	
				12,0			8,0	10,0	
				14,0			8,0	12,0	
				16,0			9,0	13,0	
				18,0		9,0	15,0		
		7,0	133	4,0		6,0			
		10,0		6,0	8,5				
		12,0		8,0	10,0				
		14,0		8,0	12,0				
		16,0		10,0	13,0				
		18,0	10,0	15,0					
		7,0	159	4,5	180	8,3			
		10,0		8,0		12,0			
		12,0		10,0		14,0			
		14,0		10,0		16,0			
		16,0		12,0		18,0			
		18,0	12,0	20,0					
		7,0	168	4,5			8,3		
		10,0		8,0		12,0			
		12,0		10,0		14,0			
		14,0		10,0		16,0			
		16,0		12,0		18,0			
		18,0	12,0	20,0					
		7,0	219	6,0		8,3			
		10,0		8,0	12,0				
		12,0		10,0	14,0				
		14,0		12,0	16,0				
		16,0		14,0	18,0				
		18,0	16,0	20,0					
300	325	8,0	108	4,0	140	9,0			
		10,0		4,0		11,0			
		12,0		6,0		16,0			
		14,0		6,0		18,0			
		16,0		8,0		20,0			
		18,0		8,0		23,0			
		22,0		9,0		28,0			

Продолжение таблицы 2

Размеры в миллиметрах

DN	D	T	D ₁	T ₁	L	Масса, кг
300	325	8,0	114	4,0	140	9,0
		10,0		4,0		11,0
		12,0		6,0		16,0
		14,0		6,0		18,0
		16,0		8,0		20,0
		18,0		8,0		23,0
		22,0		9,0		28,0
		8,0	133	5,0		11,0
		10,0		6,0		13,0
		12,0		8,0		16,0
		14,0		8,0		18,0
		16,0		8,0		20,0
		18,0		10,0		23,0
		22,0	10,0	28,0		
		8,0	159	4,5		11,0
		10,0		6,0		14,0
		12,0		8,0		16,0
		14,0		8,0		18,0
		16,0		10,0		20,0
		18,0		10,0		23,0
22,0	12,0	28,0				
8,0	168	4,0	11,0			
10,0		6,0	14,0			
12,0		8,0	16,0			
14,0		8,0	18,0			
16,0		10,0	20,0			
18,0		10,0	23,0			
22,0	12,0	28,0				
8,0	219	7,0	11,0			
10,0		8,0	14,0			
12,0		10,0	17,0			
14,0		10,0	20,0			
16,0		12,0	22,0			
18,0		14,0	25,0			
22,0	16,0	31,0				
8,0	273	7,0	11,0			
10,0		10,0	14,0			
12,0		12,0	17,0			
14,0		12,0	20,0			
16,0		14,0	22,0			
18,0		16,0	25,0			
22,0	18,0	31,0				
350	377	12,0	159	6,0	220	22,0
		16,0		8,0		29,0
		20,0		10,0		35,0
		24,0		12,0		42,0
		26,0		12,0		45,0
		12,0	168	6,0		22,0
		16,0		8,0		29,0
		20,0		10,0		35,0
		24,0		12,0		42,0
		26,0		12,0		45,0

ГОСТ 17378—2001

Продолжение таблицы 2

Размеры в миллиметрах

DN	D	T	D ₁	T ₁	L	Масса, кг
350	377	12,0	219	8,0	220	22,0
		16,0		10,0		29,0
		20,0		12,0		35,0
		24,0		14,0		42,0
		26,0		16,0		45,0
		10,0	273	7,0		20,0
		12,0		10,0		24,0
		14,0		12,0		28,0
		16,0		12,0		31,0
		20,0		16,0		38,0
		24,0	18,0	45,0		
		26,0	18,0	49,0		
		10,0	325	8,0		20,0
		12,0		10,0		24,0
		14,0		12,0		28,0
16,0	16,0	31,0				
20,0	18,0	38,0				
24,0	22,0	45,0				
26,0	22,0	49,0				
400	426	12,0	159	8,0	220	37,0
		16,0		10,0		53,0
		20,0		10,0		65,0
		22,0		10,0		71,0
		26,0		12,0		83,0
		28,0	12,0	89,0		
		12,0	168	8,0		37,0
		16,0		10,0		53,0
		20,0		10,0		65,0
		22,0		10,0		71,0
		26,0		12,0		83,0
		28,0	12,0	89,0		
		12,0	219	8,0		32,0
		16,0		10,0		45,0
		20,0		12,0		56,0
		22,0		12,0		61,0
		26,0		14,0		72,0
		28,0	16,0	76,0		
		12,0	273	10,0		27,0
		16,0		12,0		36,0
20,0	14,0	44,0				
22,0	14,0	48,0				
26,0	18,0	56,0				
28,0	18,0	59,0				
10,0	325	8,0	23,0			
12,0		10,0	27,0			
14,0		12,0	31,0			
16,0		12,0	36,0			
20,0		16,0	44,0			
22,0		18,0	48,0			
26,0		20,0	56,0			
28,0		22,0	59,0			

Окончание таблицы 2

Размеры в миллиметрах

DN	D	T	D ₁	T ₁	L	Масса, кг	
400	426	10,0	377	10,0	220	23,0	
		12,0		12,0		27,0	
		14,0		14,0		31,0	
		16,0		16,0		36,0	
		20,0		20,0		44,0	
		22,0		20,0		48,0	
		26,0		24,0		56,0	
28,0	26,0	59,0					
500	530	12,0	377	10,0	300	46,0	
		14,0		12,0		54,0	
		16,0		12,0		61,0	
		20,0		16,0		75,0	
		22,0		20,0		81,0	
		26,0		22,0		94,0	
			12,0	426	10,0		46,0
			14,0		12,0		54,0
			16,0		16,0		61,0
			20,0		16,0		75,0
			22,0		20,0		81,0
			26,0		22,0		94,0

Примечание — Масса приведена для справок.

Примеры условных обозначений:

- концентрического перехода исполнения 1, $D = 76,1$ мм, $T = 2,9$ мм, $D_1 = 48,3$ мм, $T_1 = 2,6$ мм из стали марки P9:

Переход К-1-76,1 × 2,9-48,3 × 2,6-P9 ГОСТ 17378—2001

- эксцентрического перехода исполнения 2, $D = 76$ мм, $T = 3,0$ мм, $D_1 = 45$ мм, $T_1 = 2,5$ мм из стали марки 20:

Переход Э-76 × 3-45 × 2,5 ГОСТ 17378—2001

- то же, из стали марки 09Г2С для трубопроводов, подконтрольных органам надзора:

Переход П Э-76 × 3-45 × 2,5-09Г2С ГОСТ 17378—2001

(Измененная редакция, Изм. № 1).

4.2 Толщина стенки переходов в неторцевых сечениях должна быть не менее T_1 при наружном диаметре сечения не более $1,1D_1$, а в остальных сечениях — не менее T .

4.3 Радиусы r_1 и r_2 переходов исполнения 1 должны соответствовать указанным в таблице 3, а исполнения 2 устанавливаются изготовителем в конструкторской документации с учетом применяемой технологии изготовления и обеспечения требуемых показателей прочности и надежности.

Таблица 3 — Радиусы сопряжения поверхностей переходов

Тип перехода исполнения 1	r_1	r_2
	не менее	
Концентрический	$0,4D$	$0,4D_1$
Эксцентрический	$0,3D$	$0,3D_1$

(Измененная редакция, Изм. № 1).

ГОСТ 17378—2001

4.4 По согласованию между изготовителем и потребителем (заказчиком) допускается изготовление переходов других размеров.

5 Технические условия

Технические условия — по ГОСТ 17380.

УДК 621.643.4:006.354

МКС 23.040.40

Г18

ОКП 14 6800

Ключевые слова: трубопроводы, детали трубопроводов, трубопроводные переходы, конструкция, размеры

Изменение № 1 ГОСТ 17378—2001 (ИСО 3419—81) Детали трубопроводов бесшовные приварные из углеродистой и низколегированной стали. Переходы. Конструкция

Принято Межгосударственным советом по стандартизации, метрологии и сертификации (протокол № 29 от 24.06.2006)

Зарегистрировано Бюро по стандартам МГС № 5422

За принятие изменения проголосовали национальные органы по стандартизации следующих государств: AM, KZ, KG, MD, RU, TJ, UZ, UA [коды альфа-2 по МК (ИСО 3166) 004]

Дату введения в действие настоящего изменения устанавливают указанные национальные органы по стандартизации*

Раздел 2. Заменить ссылку: ГОСТ 17380—2001 на ГОСТ 17380—2001 (ИСО 3419—81).

Пункт 4.1. Таблицу 2 дополнить размерами:

DN	D	T	D ₁	T ₁	L	Масса, кг
50	57	3,0	45	2,5	45	0,2
		3,5		2,5		0,2
		4,0		3,0		0,3
		5,0		4,0		0,3
		6,0		5,0		0,4
80	89	3,5	76	3,0	55	0,5
		4,0		3,5		0,5
		6,0		5,0		0,7
		8,0		6,0		0,9
125	133	5,0	108	4,0	80	1,3
		6,0		5,0		1,6
		8,0		7,0		2,0
		10,0		9,0		2,5
		5,0	114	4,5		1,3
		6,0		5,0		1,6
		8,0		6,0		2,0
		10,0		8,0		2,5

* Дата введения в действие на территории Российской Федерации — 2008—01—01.

(Продолжение см. с. 42)

(Продолжение Изменения № 1 к ГОСТ 17378—2001 (ИСО 3419—81))

Окончание таблицы

DN	D	T	D_1	T_1	L	Масса, кг
150	159	5,0	114	4,0	105	2,0
		6,0		5,0		2,5
		8,0		6,0		3,1
		10,0		8,0		3,8
		5,0	133	4,5		2,0
		6,0		5,0		2,5
		8,0		7,0		3,1
		10,0		9,0		3,8

Пункт 4.3. Первый абзац изложить в новой редакции:

«Радиусы r_1 и r_2 переходов исполнения 1 должны соответствовать указанным в таблице 3, а исполнения 2 устанавливаются изготовителем в конструкторской документации с учетом применяемой технологии изготовления и обеспечения требуемых показателей прочности и надежности»;

таблица 3. Наименование после слова «переходов» дополнить словами: «исполнения 1».

(ИУС № 7 2007 г.)